

Input Voltage	Wheel Ring Wattage	Max Controller Load
12V DC	6W per ring	3A per controller

Warranty and Disclaimer

Within One year after the purchase date, the original buyer may return any XKGLOW product that has failed due to a defect in materials or workmanship. Wheel rings that have one or more LEDs fail to illuminate due to a defect in materials or workmanship are covered with a one-year warranty for **the original buyer**.

Installation of this product must be performed by a licensed professional. Should the failure of the product be the result of damage occurring as a result of improper installation, alteration of the product or an act or omission on the part of the consumer, this warranty is void. XKGLOW Lighting shall not be responsible for any consequential damages which arise from the use and/or installation of the product. If the kit is installed in any manner other than specified, XKGLOW Lighting reserves the right to deny any warranty claims at the discretion of the technical support department. Any product return must include the original packaging, invoice number and a statement of the alleged defect. Upon receipt of the returned product, the company will test the product for defect. If the results of the testing do not support the warranty claim, do not reveal any defect or indicate consumer negligence in the installation and handling of the product, then the product will be returned to you and you will be charged a reshipping fee. If the product is returned from an address within the continental United States, within the first 30 days after purchase, and is found to be defective, XKGLOW Lighting will exchange or refund the original purchase expense. This offer does not extend to the cost for shipping charges on any international packages.

Additional Disclaimer Terms

Please check your local and state laws for the proper use of this product.

- Improper installation of electrical products such as lighting may cause damage to any vehicle or device to which the improperly handled or installed lighting is attached.
- Improperly installed product may cause electrical injury to persons.
- It is recommended that the kit should be installed by a licensed professional.
- XKGLOW assumes no liability for the installation of the product.
- Warranty or liability will not exceed the product purchase price, which shall be buyer's sole and exclusive remedy.

Return/Exchange Procedure

1. Email [xk@xkglow.com] to notify us of the product issue as well as the item number and name of customer on invoice.
2. We will send you the trouble-shooting guide to fix the issue, or to narrow down which of the component(s) need to be replaced. If the issue still exists, we will ask you to send back the defective items to be replaced.
3. Please send the returned item as instructed, along with claims and a telephone number where you can be reached.
4. After the returned item(s) have been accepted and inspected, we will issue a refund or replace the items ASAP. For refunds, item(s) must be sent to XKGLOW within 14 days from date of purchase. Original shipping charges are not refundable.

We always stand behind our products and are committed to our customers! For questions you may have, please contact xk@xkglow.com. We normally respond within 24 hours. (Monday-Friday).

Mounting Instructions

- Test all components before mounting:** As shown below, plug ALL units together and power on for testing. If the lights show any defects, please contact us and we will be happy to replace them for you.

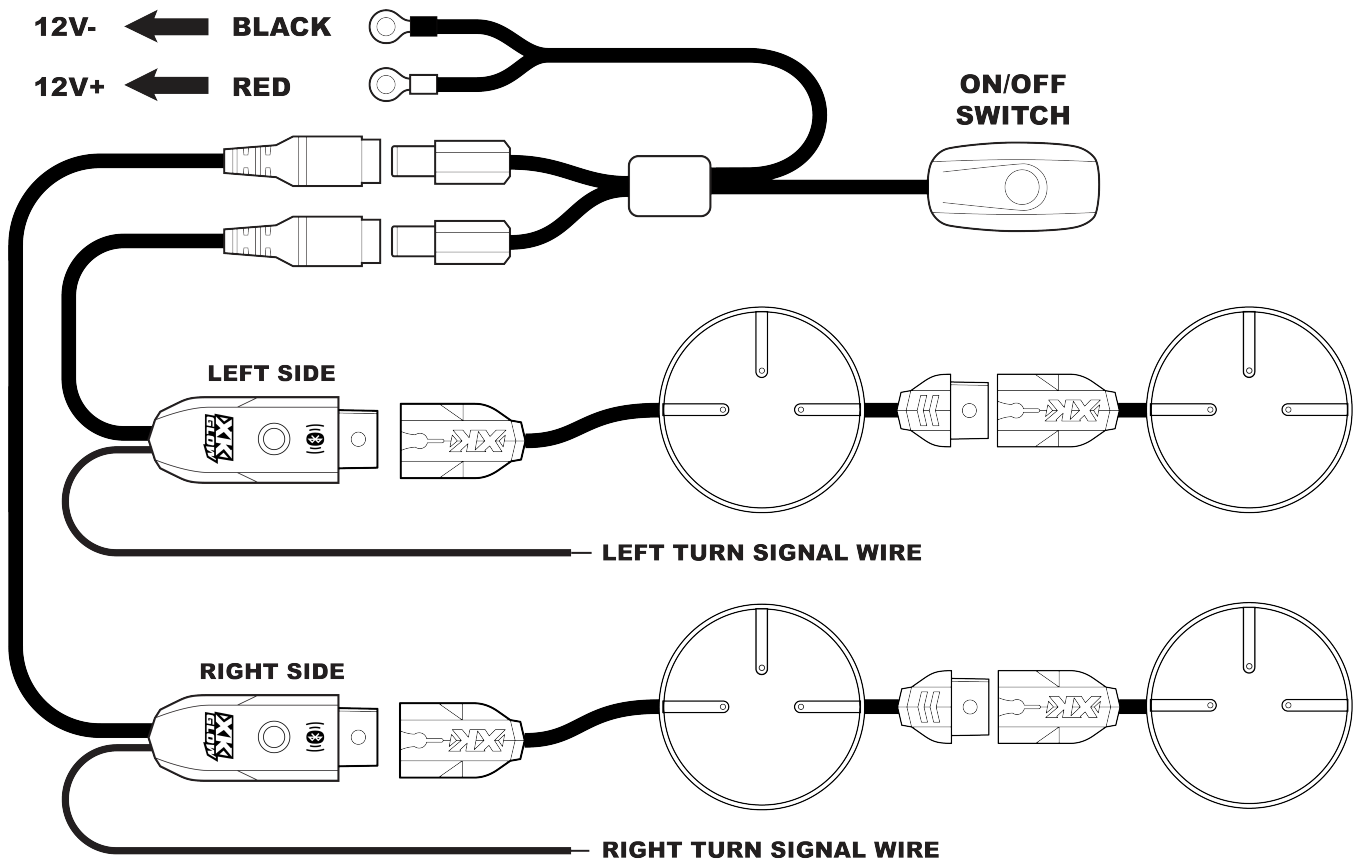

Wiring Options

- Wire Direct to Battery:** To independently control the wheel rings without your vehicle being powered on, you must wire the power wire harness directly to the battery. With this setup, the wheel rings must be turned on via the ON/OFF switch or the XKchrome App. Firmly connect the wire terminals on the harness to the positive and negative terminals on the battery.
- Wire to Ignition Source:** Wiring the power wire harness to an ignition source will make the wheel rings turn on automatically when the vehicle is powered on. Note- you will not be able to control the wheel rings independently of the vehicles power. To do this, simply wire the **red** wire on the power wire harness to an ignition wire source utilizing an add-a-fuse (not included). Ensure that the fuse is capable of handling the extra current load from the added accessories. Connect the **black** wire on the power wire harness to a nearby ground.

Wheel Ring Install

- Remove the wheels:** Using a jack and jack stands (or a lift if you're lucky enough!) secure your vehicle in place. Remove the wheels from the vehicle.
- Verify fitment of wheel rings:** Before removing the brake components, ensure that the wheel rings will fit your vehicle. Hold the ring up to the front face of the rotor and check for clearance around the caliper. Also check for wheel clearance by holding the ring up to the back side of the wheel. It must clear both to continue with installation.
- Remove brake components:** **Brake components are a vital part of your vehicle and ultimately your safety. If you are not comfortable uninstalling/reinstalling these components, please seek a professional for installation.** Remove the brake calipers and brake rotors to gain access to the dust shield. This process will vary per vehicle. Please consult your service manual if you need additional guidance.

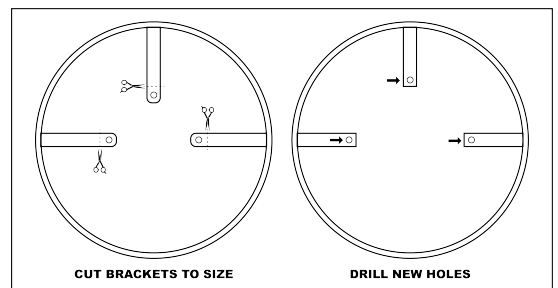

5. **Mount wheel rings:** The wheel rings mount to the back side of the dust cover. Slide the wheel ring over the dust cover. If your vehicles dust covers are oversized, you may need to shorten the mounting brackets on the wheel rings. See diagram above. Following the diagram below, install the wheel rings. Center the wheel ring and mark the 3 holes to drill on the dust cover. Drill the holes using an 1/8" drill bit. Using the supplied bolts and nuts, securely mount the wheel ring. **Please note, the bolts should go in towards the inside of the vehicle with the nuts on the back side of the dust covers. This will ensure clearance when the brake rotor goes back on.** Reinstall the brake rotors and calipers onto the vehicle. The illustration below shows the wheel ring installed with the brake rotor and caliper in place.

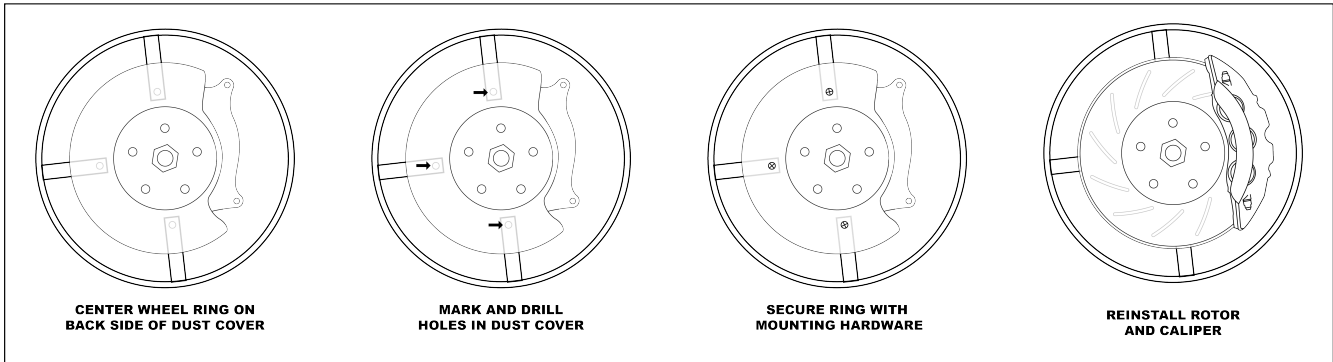

6. **Route RGB Wiring:** There are two lengths of wire included in the kit- 2pc 6ft wire and 2pc 12ft wire. The 6 foot wires are to reach the front wheel rings and the 12 foot wires go between the front and rear wheel rings. Starting at the battery or wherever you are going to mount the XKchrome controllers, begin routing the 6 foot wires to the wheel rings. Ensure that the smaller male end is being fed towards the wheel rings. Keep the wires away from hot or moving parts. When you reach the wheel wells, plug the front wheel rings into the 6ft extension wires. Plug the 12 foot wires into the other end of the front wheel rings and route it back to the rear wheel rings. Using zip ties, secure the wheel ring wires to non-moving parts to ensure nothing gets snagged or pulled when driving.

7. **Route power wiring harness:** Mount the ON/OFF switch in a convenient location. Route the two DC plugs toward each side of the vehicle. Using zip ties, secure any loose wiring.

8. **Install XKchrome Mini Controllers:** Plug the XKchrome Mini controllers into the DC plugs from the power wiring harness. Plug the other end of the Mini controllers into one of the extension wires going to the front wheel rings. Plug the left side wheel rings into one controller and the right side wheel rings into the other.

9. **Tap into the + turn signal wires:** Please check service manual specific to your make and model to verify positive turn signal wires. Tap the Yellow wire from the Mini controller into the corresponding side's turn signal wire. If the Mini controller is plugged into the LEFT wheel rings, ensure that the yellow wire from that controller goes to the LEFT positive turn signal wire.

10. **Clean up wiring:** Using zip ties, secure any loose wiring. To ensure that wiring has enough slack, turn the steering wheel full lock left and right and inspect. Place the included 3M tape onto the back of the XKGLOW plugs.

11. Re-install your wheels, power on, download the **XKchrome App**, and enjoy! **You must pair to BOTH controllers separately as they each have their own Bluetooth signal.**

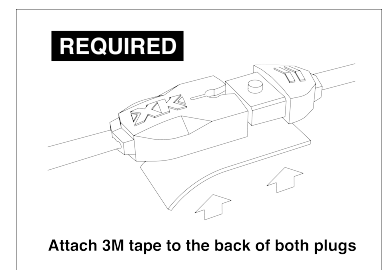
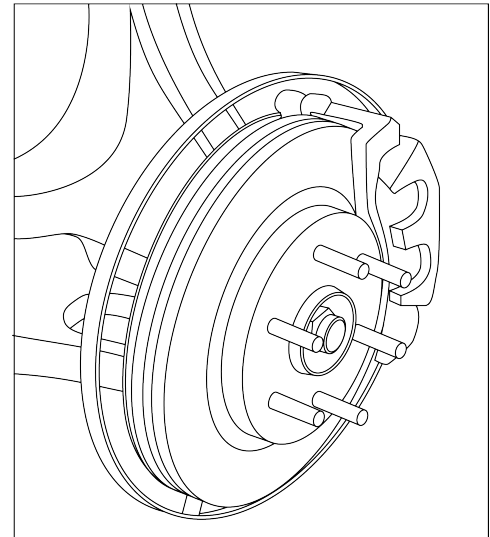

Please note: There are multiple XKGLOW apps on the App Store. Only the XKchrome App will work with the XKchrome Bluetooth Controller. The App icon is pictured here.